

KW 109 Supermatch



INSTRUCTION MANUAL

KW 109 SUPERMatch.

The KW109 SUPERMatch is a combination of the following KW products, all in one cabinet:

1. KW E-Z Match ATU (High Power Model)
2. KW103 SWR/Watt Meter
3. KW Antenna Switch
4. KW Dummy Load

The cabinet is the same as used for the KW2000A/B/E AC Power Supply and exactly matches the KW2000A/B/D/E, KW Vespa, KW204, KW1000, KW202, etc. The KW109 SUPERMatch enables the output of a transmitter to be matched to an antenna system and provides additional protection against TVI, over the bands 10-80 metres. Standing-Wave-Ratio on the antenna can be compared with the purely resistive dummy load or the dummy load can be used to load a transmitter before the antenna is connected for matching by means of the E-Z Match circuitry. The Wattmeter is calibrated in two ranges, 0-100 and 0-1000 watts. The Selector switch provides output from the transmitter, through the E-Z Match, to two different antennas. In addition to the coaxial sockets at the rear of the Unit, there are two pairs of sockets for use with balanced feeders; these sockets are not switched. A popular arrangement for the KW109 SUPERMatch is the permanent connection of the KW Trap Doublet for 80 and 40 metre operation and a Triband Beam for 10, 15 and 20 metres. The correct antenna can be switched to the appropriate band by means of the selector switch. For an easy check on band conditions, the antenna can be switched direct to the Receiver, without the necessity of re-tuning the E-Z Match, by using the "Direct" positions of the antenna selector switch. These positions can be used for transmission, if required.

FRONT PANEL The controls on the front panel are "METER SENSITIVITY" for setting the SWR Meter to full scale when meter switch is in FWD. "FWD-RFLD-HIGH-LOW" for switching the meter to SWR Forward voltage, SWR Reverse voltage, WATTMETER high power and WATTMETER low power. The meter is 3-1/4" square, directly calibrated in Standing-Wave-Ratio and Watts with two ranges 0-100 watts and 0-1000 watts. The two Tuning controls used for tuning the E-Z Match are equipped with slow motion drives. The main switch, is a six way four pole heavy duty ceramic switch, with the following positions -
Dummy Load, ANT. A Direct, ANT. A 80/40, ANT. A 20/15/10, ANT. B 20/15/10, ANT. B. Direct.

REAR PANEL All coaxial sockets are SO239 (UHF) type and require PL259 matching connectors (not supplied). Mounted on the rear panel are three SO239 sockets for the antenna connectons including one for the input socket to which the output of the transmitter is connected. A spare hole is provided for an extra socket, if required. Two pairs of terminals are also provided for use with balanced feeders.

FREQUENCY RANGE Amateur Bands are covered in 2 ranges, 80-40 metres and 20, 15 and 10 metres. The internal and external connections of the KW109 must be arranged so that the appropriate connections of the KW109 must be arranged so that the appropriate antenna is connected to the antenna tuner proper output terminals. Other possible arrangements for using more than two antenna systems can be accomodated by simple modification to the circuits provided.

GENERAL CHARACTERISTICS The KW109 SUPERMatch will match an antenna feed impedance of approx. 30-2500 ohms on 10-15 and 20 metres and 30-1000 ohms on 40 and 80 mtrs. Power restrictions on the unit apply mainly to the E-Z Match ATU. This part of the unit is suitable for transmitters with 1KW PEP and on the other end of the scale, 50 watts PEP minimum for full scale indication. The Selector Switch wafers are ceramic

operated well within their ratings when the power limitations are observed. It is recommended that reduced power be used when adjusting the E-Z Match, until a good SWR is achieved.

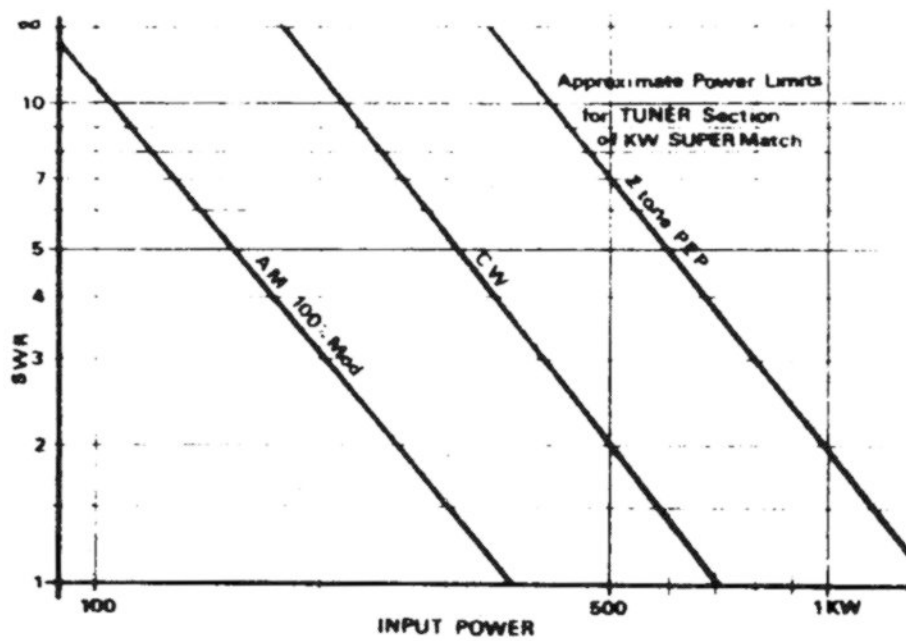

OPERATING INSTRUCTIONS

1. Turn Selector Switch to "LOAD".
2. Turn Meter Switch to High Power or Low Power depending on the transmit power of your equipment.
3. Tune up transmitter into the LOAD observing limitations described in the paragraph on the DUMMY LOAD.
4. Adjust Transmitter to about 15 watts output and go back to receive.
5. Turn Selector Switch to desired antenna using E-Z Match - ANT. A 80/40 - ANT. A 20/15/10 or ANT. B 20/15/10.
6. Tune the receiver to a signal near the operating frequency.
7. Adjust the two Tuning Controls for maximum receive signal.
8. Turn meter switch to SWR-FWD.
9. Turn on Transmitter and adjust SWR sensitivity control to give full scale on meter.
10. Turn Meter Switch to SWR REFL.
11. Carefully adjust tuning controls to give minimum SWR (in most cases an SWR of 1:1 should be possible).
12. Record the position of the tuning controls for easy reference.

NOTE: 1. When first tuning the SUPERMatch on a new frequency or new antenna, ALWAYS adjust the transmitter into the Dummy Load as a first step. This ensures that the transmitter is tuned and loaded correctly.

2. If the antenna SWR is high, and it is not possible to achieve a 1:1 SWR through the Tuner, lengthening or shortening the feed line may make a match possible.

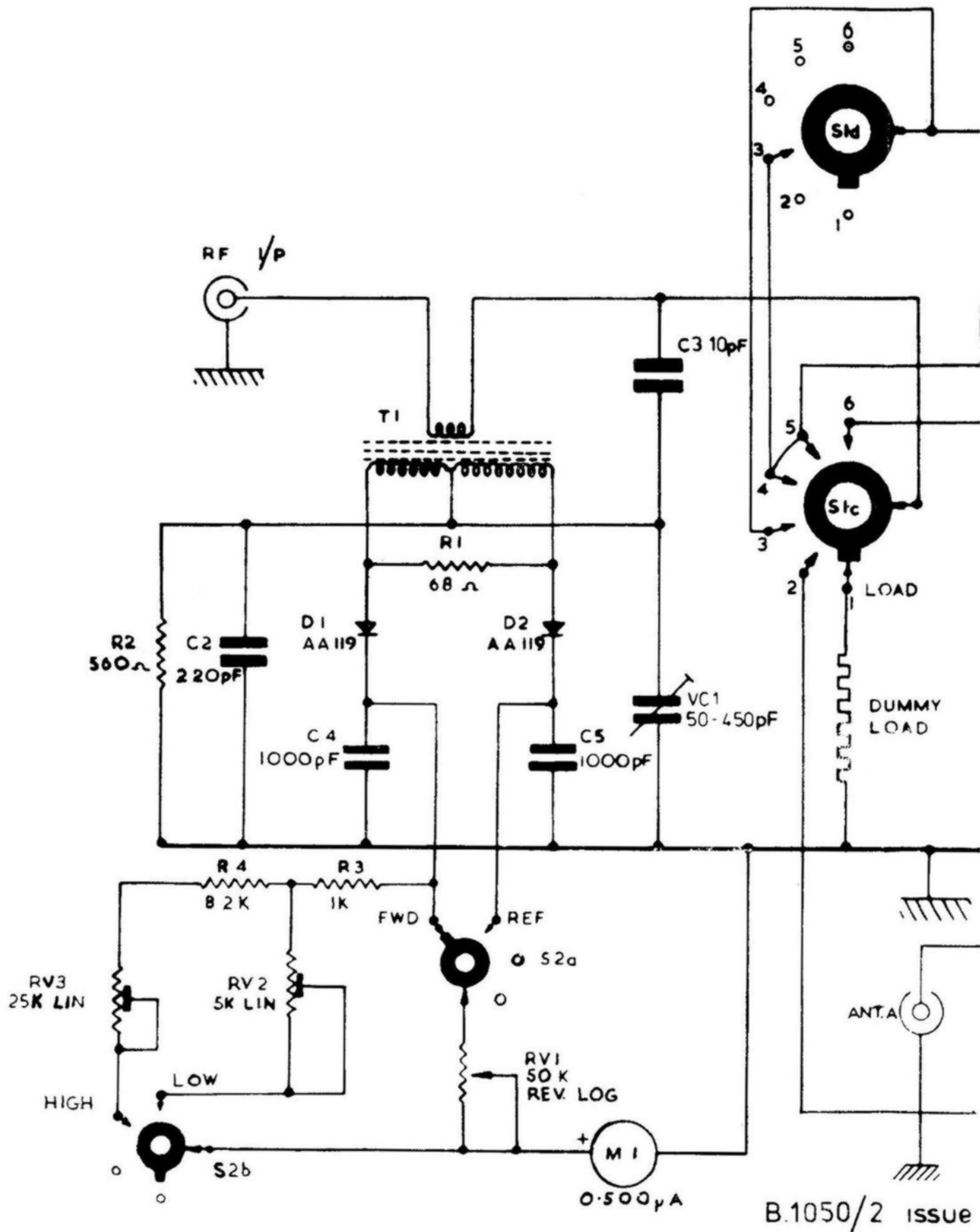

SWITCH POSITIONS (S1)

- 1 - LOAD
- 2 - A DIRECT
- 3 - A 80/40
- 4 - A 20/15/10
- 5 - B 20/15/10
- 6 - B DIRECT

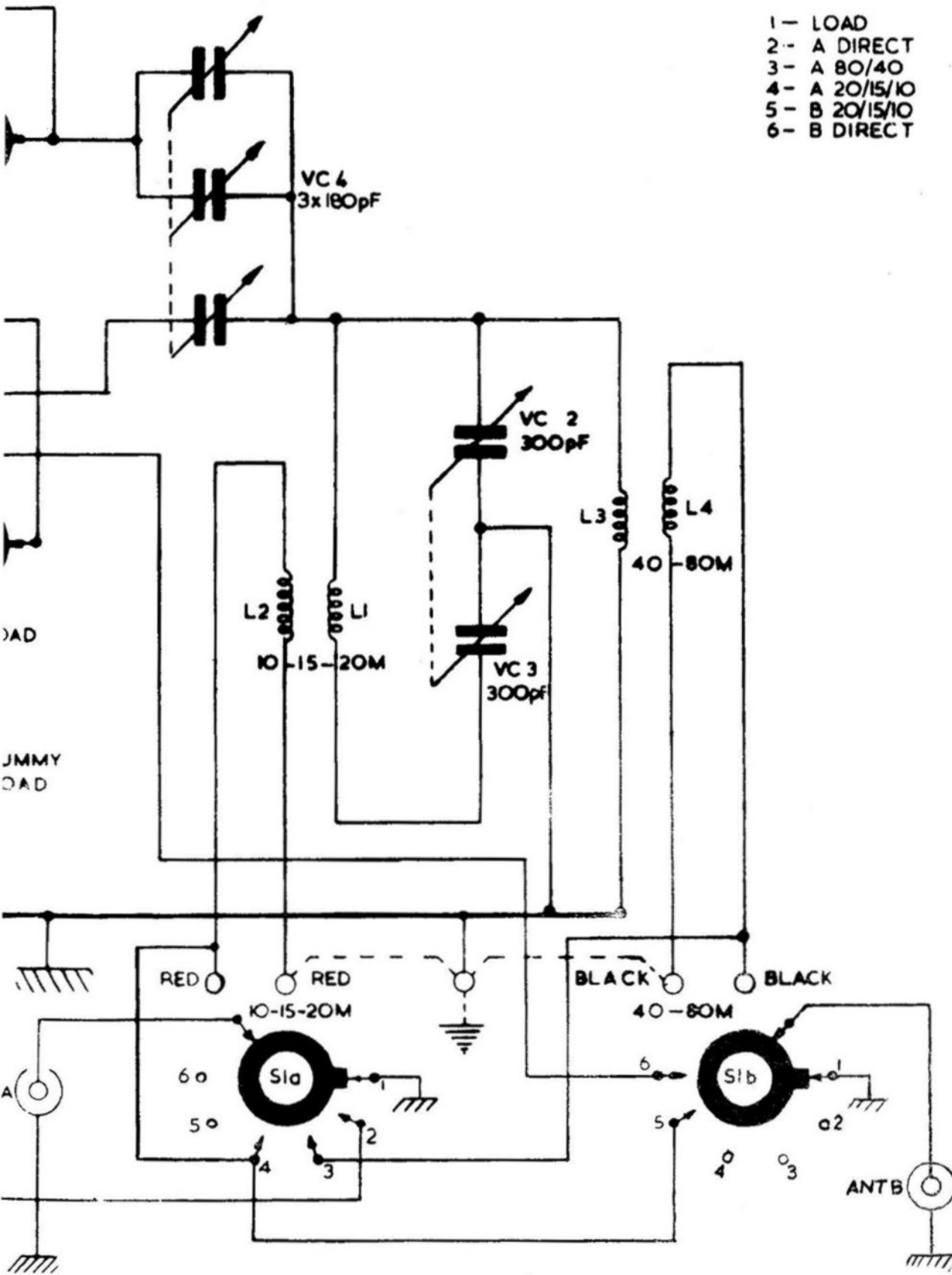

issue 3

KW 109 High Power Supermatch

USE OF BALANCED FEED LINES If 400-600 ohm balanced feeders are used for both 80/40M antenna, and the 20/15/10 metre antenna, appropriate knife switches (DPST) must be used to disconnect the unused feeders. DO NOT OPERATE the KW109 SUPERMatch with CONNECTIONS MADE TO BOTH OUTPUTS. When a coaxial feeder is used for one antenna and balanced feeders are also used ON THE SAME RANGE, a DPST Knife Switch must be used so that the appropriate terminal can be grounded for the coaxial line. The knife switch must be mounted CLOSE to the SUPERMatch so that the ground lead is SHORT.

Should an antenna be employed, using 75 ohm twin feeder, we recommend a Balun (such as the KW Balun 52/75 ohm) be used and mounted immediately behind the KW109 SUPERMatch. Connection by about 6 inches co-ax cable between input to Balun and SO239 sockets A or B at rear of KW109. The twin feeder is terminated at the Balun "Antenna" connections.

USE OF MORE THAN TWO ANTENNAE Up to three additional antennas can be switched on the 20/15/10M or 40/80M outlets provided on the KW109 SUPERMatch by employing a KW ANTENNA SWITCH.

INSTRUCTIONS for removing Cabinet

Carefully remove the unit from the cabinet as follows:

1. Remove two front feet.
2. Remove two screws at the bottom rear of the cabinet.
3. Remove the nickel-plated screw on the top front of the cabinet (take care not to damage the cabinet). Use the correct size screw driver which is not blunted to remove this screw.
4. Slowly and carefully slide the unit out of the front of the cabinet taking care not to scratch the painted cast escutcheon ring.
5. Set the cabinet aside and away from the work area so it will not get scratched.

DUMMY LOAD The Power limitation of the dummy load is in the temperature rise at the "skin" of the resistor which must not exceed 300°C. This means that 1kW can be applied for 5 seconds max. time. 100 watts raises the temperature to the limit in about 6 minutes and 50 watts can be run for 20 minutes.

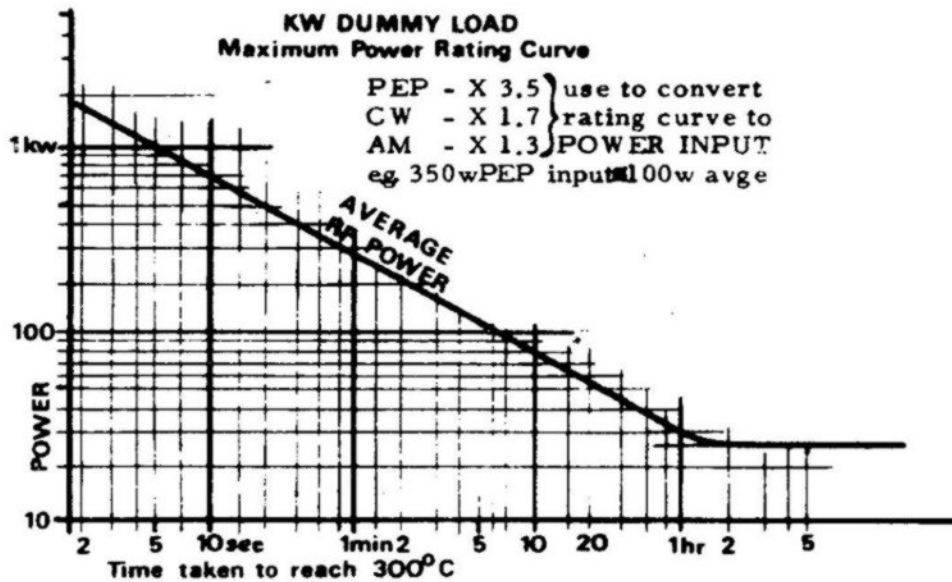

Decca Communications reserve the right to change prices and specifications without notice and without incurring obligation.

DECCA COMMUNICATIONS Ltd.,
Cramptons Road,
Sevenoaks,
Kent. TN14 5EA. ENGLAND. Telephone No. 0732 - 50911

Connect to BEAM Antenna

Connect to KW Trap Dipole

Connection's for Balanced Feeders

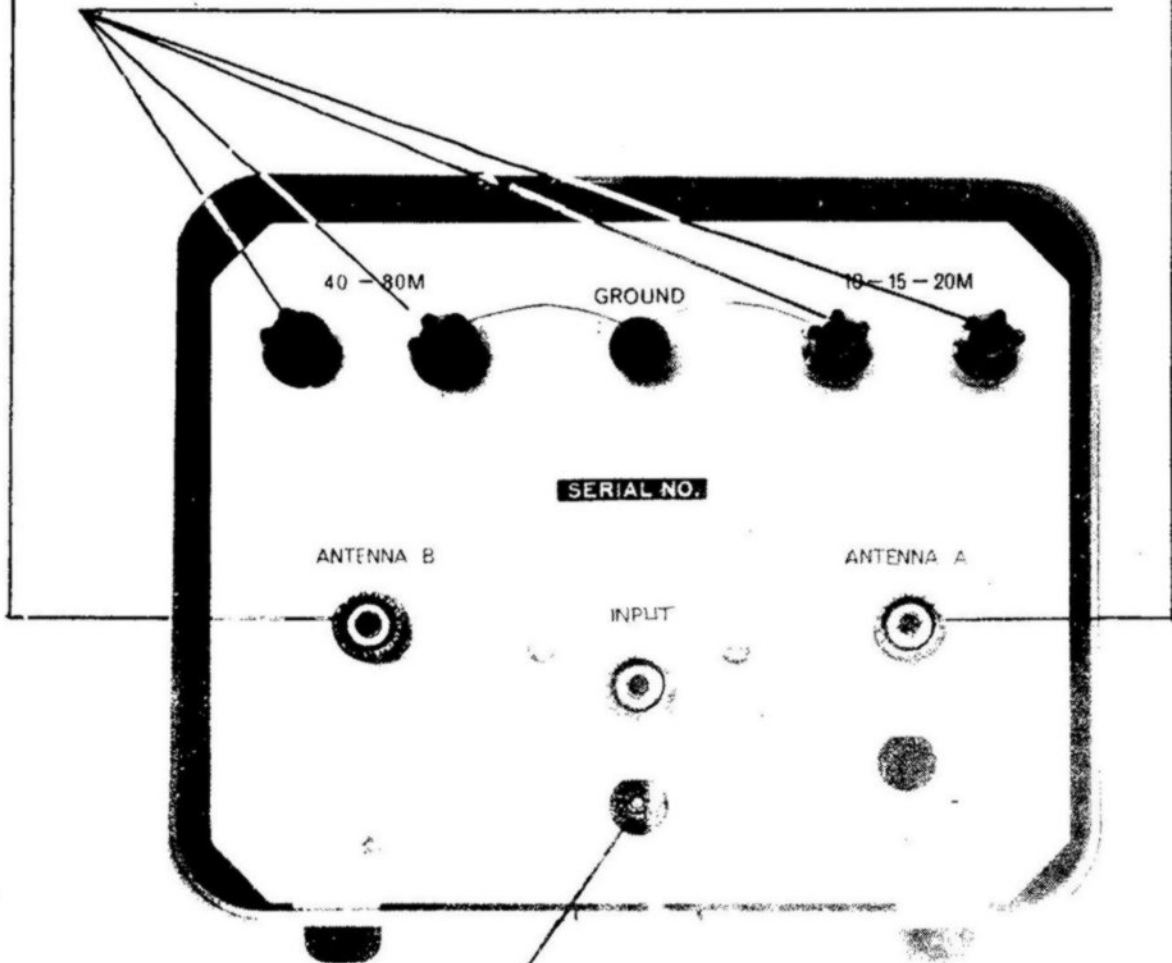

Factory Adjusted

DO NOT TOUCH

KW 109

Rear Panel

Communications

Equipment



Amateur

and Professional