

## **An Extensive W3EDP Antenna Study**



**WOESE and “Picnic Table” W3EDP Antenna**

There seems to be a lot of discussion out there about the W3EDP antenna. I thought I would do my own “KCOPET style” analysis. This has turned out to be a pretty extensive analysis of this antenna.

A couple of my local friends have been using this antenna for portable operation with fine business success. So I am using a “picnic table portable” application of the W3EDP antenna for this study. It seems there are many ways to set up this antenna. The antenna is really just 2 wires, an 84’ long wire and a 17’ short wire. I decided to look at several configurations to see which might stand out; the “easy” setup with the short wire thrown on the ground, an end fed zep configuration, one with the short wire about 2’ above ground and a simple 84’ end fed wire (sketches are below). I don’t want to tackle the discussion of whether the short wire is a “counterpoise” or not. I will just stay away from the counterpoise discussion.

Also just for the sake of history or nostalgia, the namesake of W3EDP was H. J. Siegel and the W3EDP antenna design was presented in the March, 1936 QST by Yardley Beers, W3AWH.

Here are some assumptions:

- Average ground conditions.
- The operator is using some sort of matching network or antenna tuner at the feed point. I show the actual impedance at the feed point minus any type of matching network; there are many strategies for matching this antenna to the transmitter.
- A “typical” configuration of the wires based on our “picnic table” setup. The long wire is more or less an inverted L.

The following includes an analysis using EZNEC. As a general disclaimer, the results of a modeled antenna are never perfect. The model will give a pretty good feel for antenna performance, but actual results will probably vary from the output of the model (and this study shows a potential weakness in EZNEC).

## General

Configuration A is the “easy” setup with the short wire thrown on the ground in the same plane as the long wire. The long wire is made up of wires 1 and 2 in the diagram. The short wire is made up of wires 3 and 4. The top wire (wire 2) is 20 feet above ground.

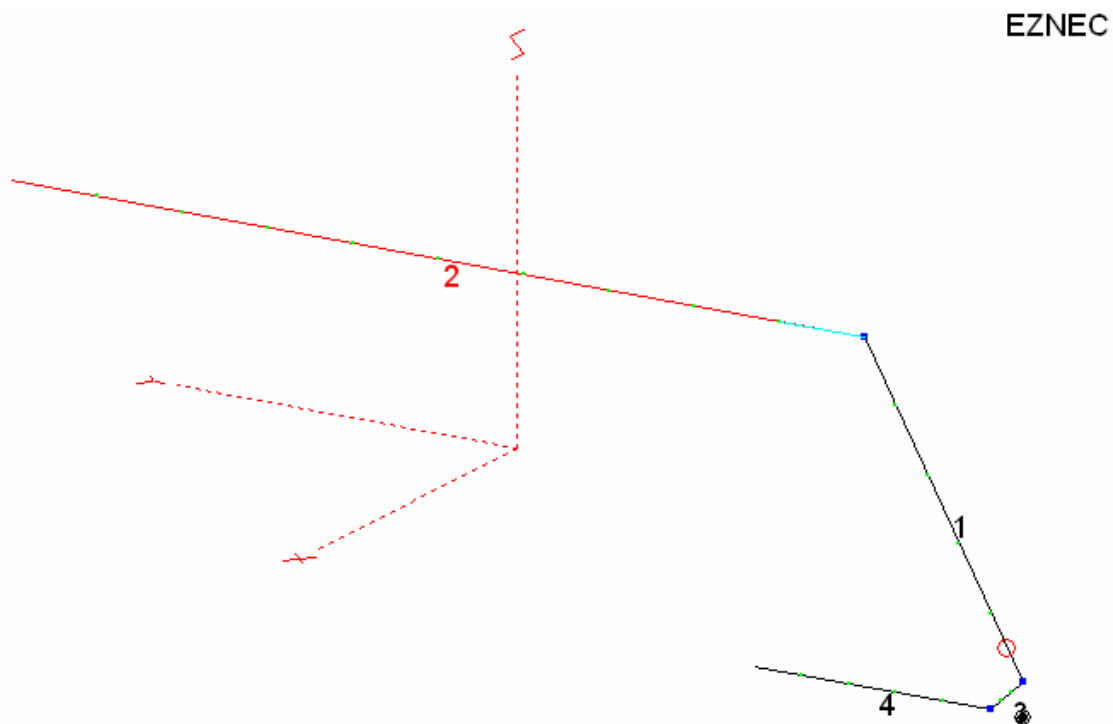

Configuration B is uses the short wire as half of a parallel feed line (end fed zep). Wires 1 and 4 on the diagram make up the parallel feed line, wire 3 is the feed point. Wire 2 is 20 feet above ground.

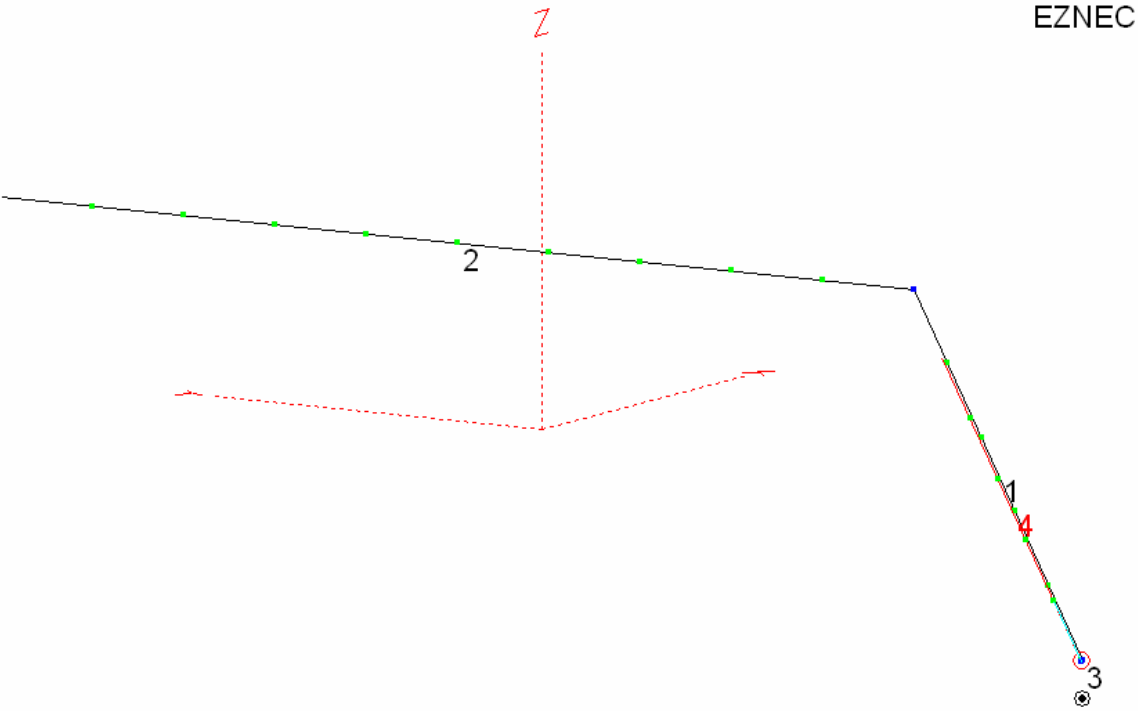

Configuration C is similar to A with the short wire (wire 3) about 2' above ground.

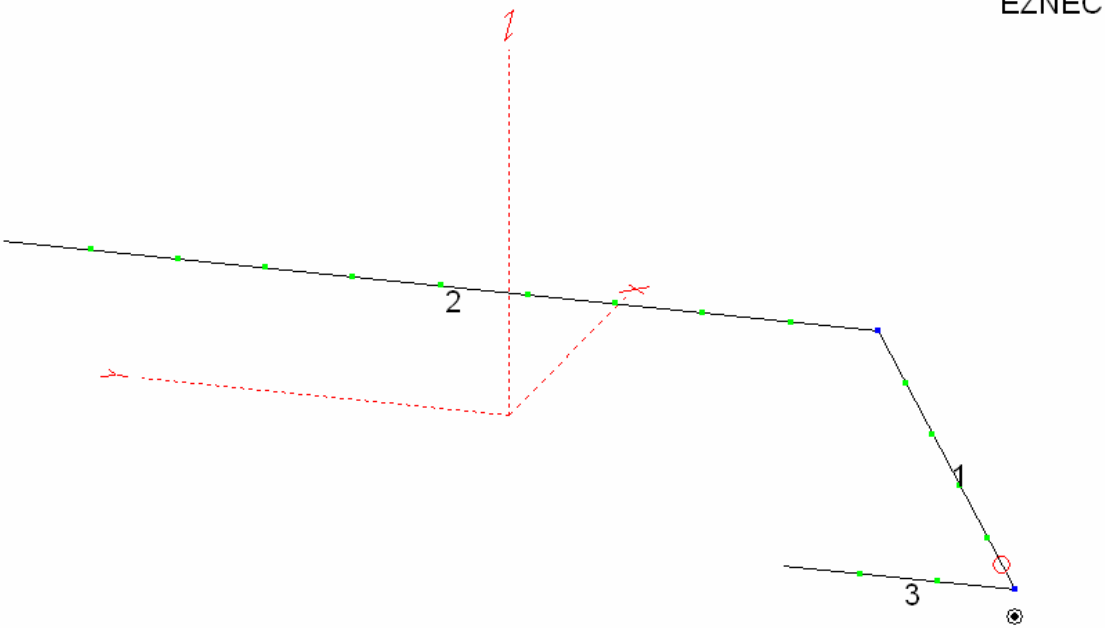

Configuration D is simply an end fed long wire.

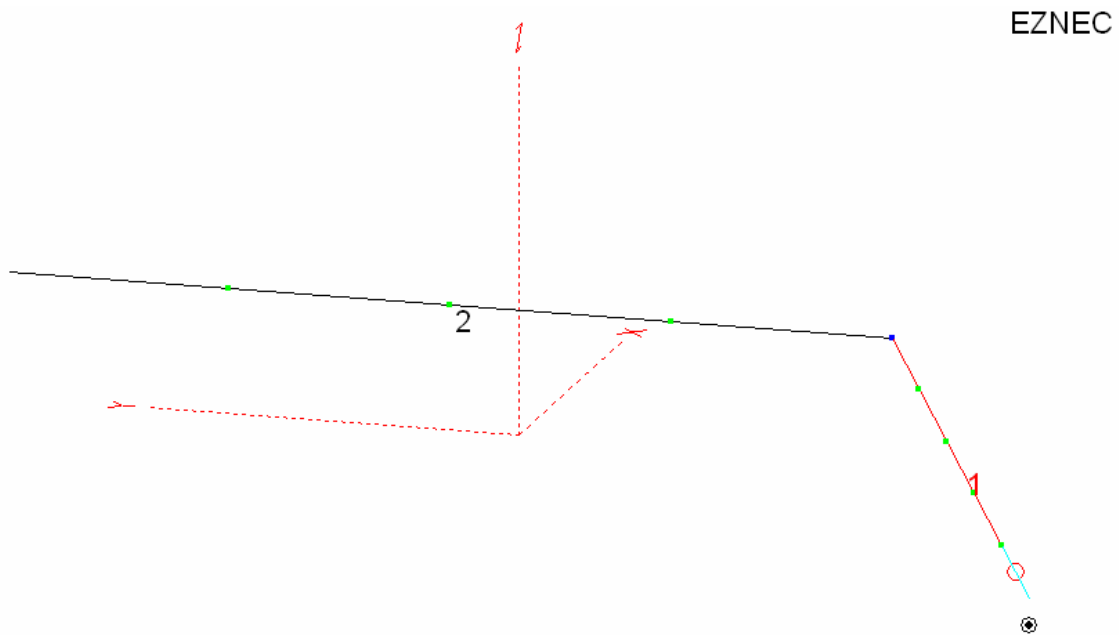

### **Conclusion:**

This is one case where the analyzed and real world results do not necessarily agree. The analyzed results seem to indicate that the end fed zep (EFZ) configuration (B) produces somewhat better gain on every band over the other configurations. Otherwise, the radiation patterns are very similar. The 40-meter pattern appears to be a very high angle pattern in all cases.

In my real world tests, though I did not find the EFZ configuration to be a very good performer. In a direct comparison between the EFZ, the long wire configuration and a basic dipole and, the dipole and long wire were definitely the star performers.

My recommendation; stick with the end fed wire, it is simple and it works. A 9:1 or 4:1 transformer (balun or unun) would be beneficial in most cases (in combination with an antenna tuner). (See my [9:1 Unun](#) as a possibility). The “ground” wire appears to be optional, but probably ought to be included in an antenna “kit”.

## Analysis:

First I took a typical situation of 40 meters and looked at the azimuth plots at a 45 degree takeoff angle.

### Configuration A (Short Wire on Ground):

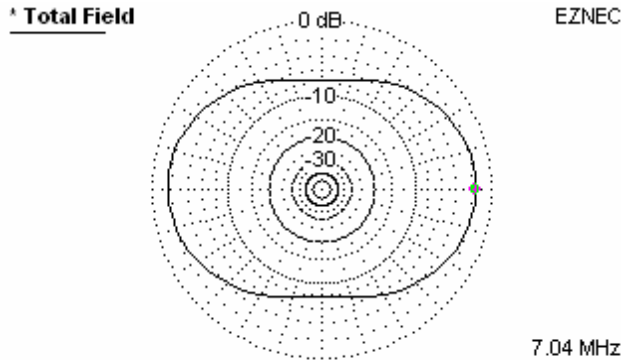

Azimuth Plot	Cursor Az	0.0 deg.
Elevation Angle	Gain	6.02 dBi
Outer Ring		0.0 dBmax
		-1.65 dBmax3D

3D Max Gain	7.66 dBi
Slice Max Gain	6.02 dBi @ Az Angle = 0.0 deg.
Front/Side	5.77 dB
Beamwidth	103.6 deg.; -3dB @ 309.8, 53.4 deg.
Sidelobe Gain	6.02 dBi @ Az Angle = 180.0 deg.
Front/Sidelobe	0.0 dB

### Configuration B (EFZ with 0.1' Parallel Wire Spacing):

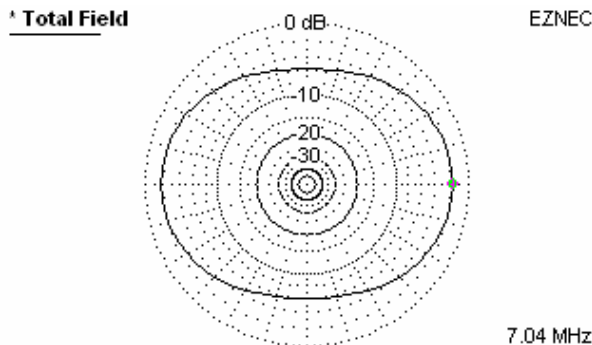

Azimuth Plot	Cursor Az	0.0 deg.
Elevation Angle	Gain	6.85 dBi
Outer Ring		0.0 dBmax
		-1.74 dBmax3D

3D Max Gain	8.59 dBi
Slice Max Gain	6.85 dBi @ Az Angle = 0.0 deg.
Front/Side	4.03 dB
Beamwidth	123.9 deg.; -3dB @ 299.7, 63.6 deg.
Sidelobe Gain	6.85 dBi @ Az Angle = 180.0 deg.
Front/Sidelobe	0.0 dB

### Configuration C (Short Wire Above Ground):

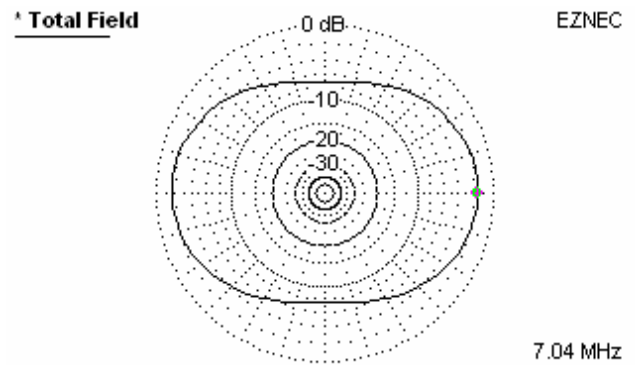

Azimuth Plot	Cursor Az	0.0 deg.
Elevation Angle	Gain	5.97 dBi
Outer Ring		0.0 dBmax
		-1.69 dBmax3D

3D Max Gain	7.66 dBi
Slice Max Gain	5.97 dBi @ Az Angle = 0.0 deg.
Front/Side	5.5 dB
Beamwidth	105.8 deg.; -3dB @ 308.5, 54.3 deg.
Sidelobe Gain	5.97 dBi @ Az Angle = 180.0 deg.
Front/Sidelobe	0.0 dB

### Configuration D (End Fed Wire):



Azimuth Plot	Cursor Az	0.0 deg.
Elevation Angle	Gain	5.94 dBi
Outer Ring		-0.01 dBmax
		-1.69 dBmax3D

3D Max Gain	7.63 dBi
Slice Max Gain	5.95 dBi @ Az Angle = 5.0 deg.
Front/Back	0.07 dB
Beamwidth	107.9 deg.; -3dB @ 309.9, 57.8 deg.
Sidelobe Gain	5.95 dBi @ Az Angle = 175.0 deg.
Front/Sidelobe	0.0 dB

I also ran a sampling on other bands and found similar results; nearly identical radiation patterns with a little more gain on the end fed zep (EFZ) configuration. For all practical purposes configurations A, C, and D appear the same using EZNEC.

In the above analysis, for the EFZ (Configuration B) I placed the parallel wires 0.1' apart which is close to 450 ohm ladder line. I also tried some other parallel wire spacing as follows.

EFZ with 0.1' parallel wire spacing:

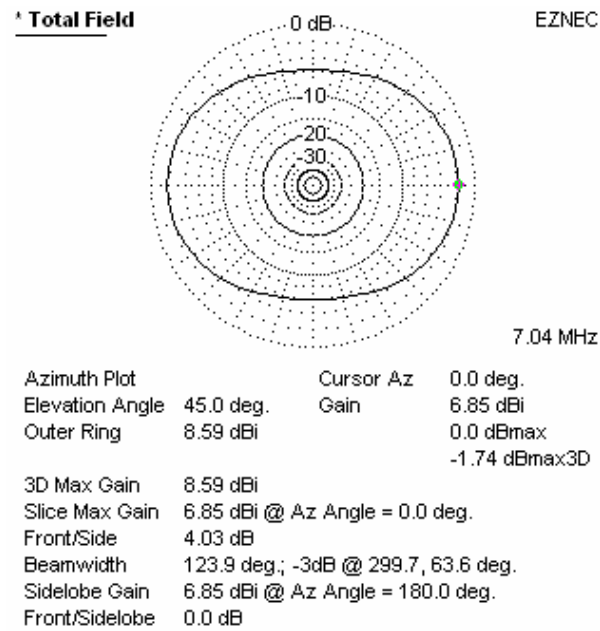

Feed point data:

Impedance = 19.16 - J 513.6 ohms  
 SWR (50 ohm system) > 100  
 (450 ohm system) = 54.105

EFZ with 0.04' parallel wire spacing (similar to 300 ohm TV feed):

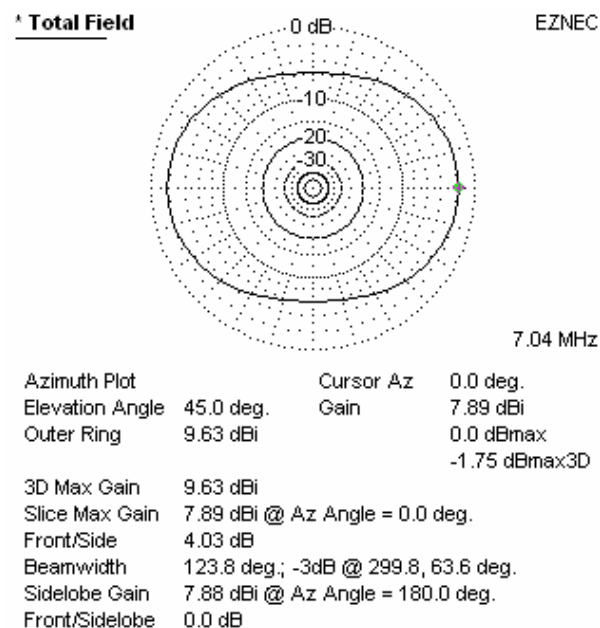

Feed point data:

Impedance = 15.6 - J 410.5 ohms  
 SWR (50 ohm system) > 100  
 (450 ohm system) = 52.874

The narrowest spacing EZNEC would let me do on parallel wires is 0.02' (about 1/4"). This is a little wider than most zip cord, but should be a close approximation.

EFZ with 0.02' parallel wire spacing:

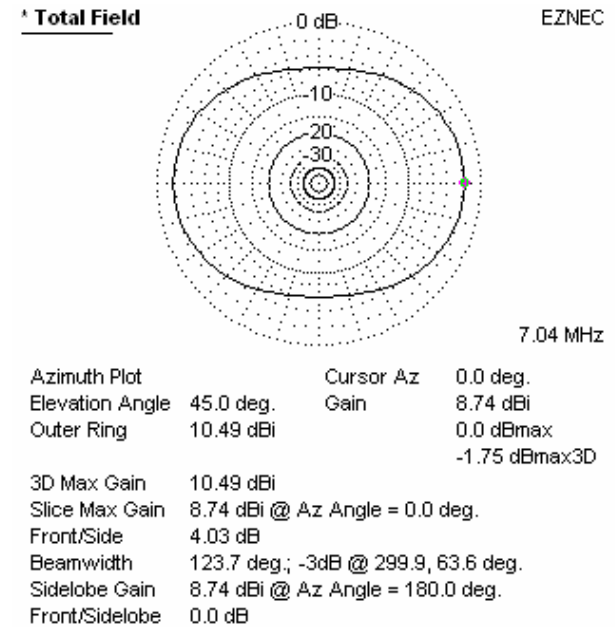

Feed point data:

Impedance = 12.64 - J 338.7 ohms  
 SWR (50 ohm system) > 100  
 (450 ohm system) = 55.790

EZNEC seems to indicate that the narrower the parallel wire the better the gain and relatively minimal change to feed point impedance. Zip cord is more "portable friendly" than ladder line (and cheaper too).

However, I am concerned about the accuracy of EZNEC on this issue of closely spaced wires. In my field testing, the EFZ configuration did not fare very well (see below).

SWR Sweeps. The next step I took is to look at the SWR sweep of the EFZ (using EZNEC) to see where there might be other points of resonance. Here is the sweep at 50 ohm impedance.

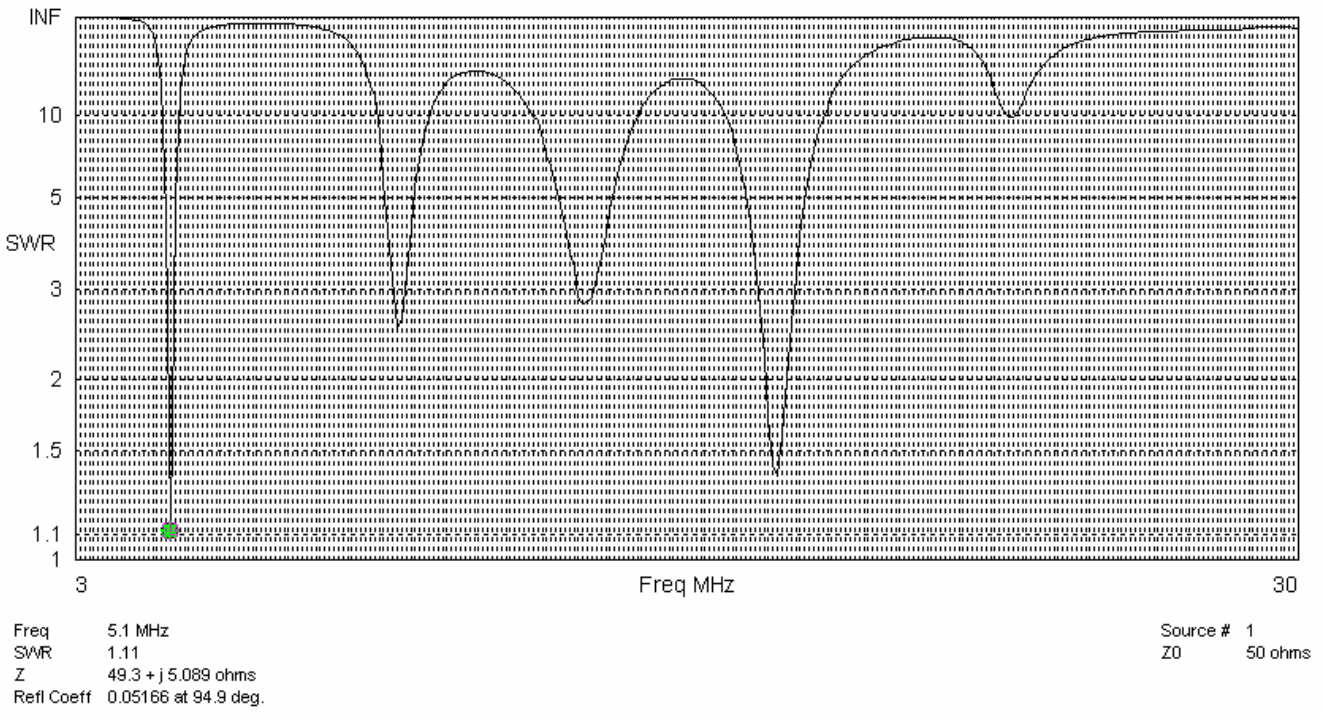

The EZNEC model indicates resonant dips at 5.1 MHz (60 meters), in 30 meters, 20 meters and close to 17 meters.

Also here is an SWR sweep for 450 ohms. This gives an idea of the benefit of a 9:1 transformer (balun or unun).

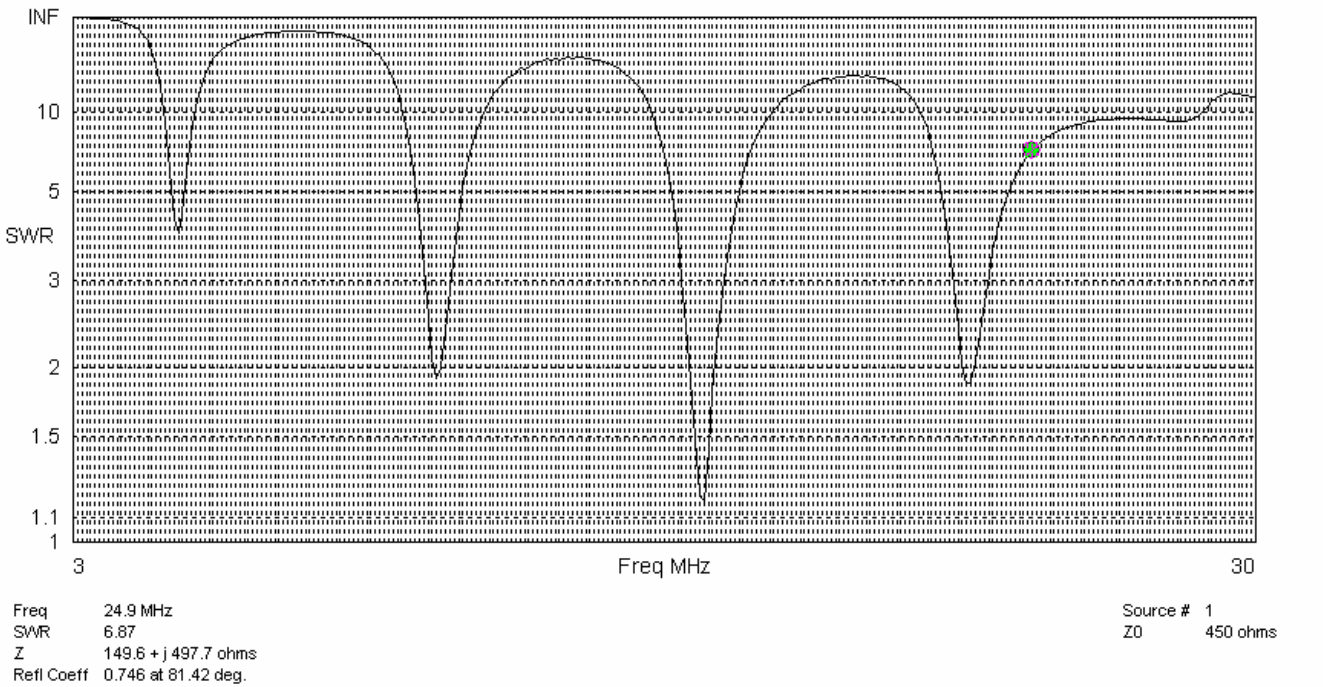

The 9:1 transformer appears to help to bring the very high SWR points (i.e. 40 meters) “out of the clouds”. Also note that it indicates a region in the 12 and 10 meter bands less than 10:1 SWR.

**Field Testing.** I will summarize a handful of field experiences with this antenna.

July 2005 - Flight of the Bumble Bees (FOBB). W0ESE and myself operated together in Boone County, MO. We used three different antennas; a 20 meter vertical, a 20 and 40 meter crossed dipole and a W3EDP. This was my introduction to the W3EDP. Bryan and I experimented with the W3EDP in configurations A and D. I do not have good documentation of the testing, but I went away with 2 observations; 1) the antenna definitely works and 2) the antenna performed about the same with or without the short “ground” wire.

July 2008 - Flight of the Bumble Bees. Both W0ESE and K9ZTV used a W3EDP antenna approximately in configuration A and both with good success. I used a crossed dipole with similar results.

November 2008 - "QRP in the Park". W0ESE again set up his W3EDP in configuration A with definite success. I set up a similar antenna and experimented with configurations A and D. I also was experimenting with a 9:1 Unun. I also had good success with this antenna. Again, I discovered that the short “ground” wire did not seem to matter.

December 2008 – My Front Yard. I set up the EFZ configuration similar to configuration B. I wanted to dig into the EFZ configuration and do some measuring.

In my junk box, I found ribbon cable that looks like it might work for this antenna. This is a 3-conductor cable. I put together a W3EDP using this ribbon cable and for now left all 3 conductors in place. One conductor is part of the 84’ long wire and the other two are left hanging for now for testing.

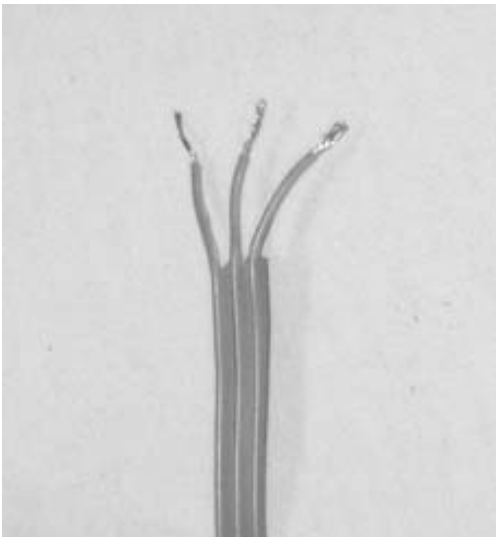

I set the antenna up similar to the proposed EFZ configuration and connected it to the antenna analyzer. I tried both of the hanging leads for comparison. Here are the results. I scanned the entire HF band for dips and frequencies of interest. It was a cold afternoon and getting dark, so I could not do any more testing, but let’s see what we have at this point. I did not have a chance to do any on-air testing with this setup.

The MFJ analyzer cannot distinguish between inductive or capacitive inductance, so I only list X in the positive value. Also note that the analyzer measures SWR based on a 50 ohm feed.

<u>Middle Wire Grounded</u>				<u>Outside Wire Grounded</u>			
<u>Frequency</u>	<u>SWR</u>	<u>R</u>	<u>X</u>	<u>Frequency</u>	<u>SWR</u>	<u>R</u>	<u>X</u>
4.0 (Dip)	3.9	170	65	4.0 (Dip)	3.8	165	50
7.0	>25	10	140	7.0	>25	15	200
9.4 (Dip)	1.6	55	20	9.2 (Dip)	1.8	65	30
10.1	3.3	75	70	10.1	4.7	180	85
14.0	23.2	10	75	14.0	17.8	15	75
20.2 (Dip)	8.4	350	100	20.2 (Dip)	10.3	360	150
21.0	22.1	490	400	21.0	>25	490	400
25.7 (Dip)	4.5	160	100	25.7 (Dip)	4.4	165	85
28.0	>25	30	140	28.0	>25	25	355
31.4 (Dip)	2.1	70	40	31.4 (Dip)	2.6	95	45

This setup yields 4 resonant dips in the HF range as did the EZNEC sweep, but at different places. I also found a dip just above 10 meters. My suspicion is that EZNEC does not model the closely spaced wires very well.

The net result, though of this study is that there is very little difference between the middle wire and the outside wire with the ribbon cable and a somewhat better SWR on a couple bands with the narrow spacing. Since the narrow spacing seems to hold promise, my next step was to build an EFZ W3EDP using zip cord wire.

[July 2009 - Southeast Missouri](#). I constructed an EFZ W3EDP from #18 speaker wire for this trip. The antenna performance was just so-so. Most of my signal reports were poor. I used my [9:1 Unun](#) on 40. Oddly enough, the unun actually *lowered* the impedance to about 2 ohms on 40 (from about 7 ohms), but my K2 tuner was better able to match it that way. The unun also helped on 20 meters. I found this version of the W3EDP to be resonant on 30 but did not make any contacts on 30.

I also ran a sweep of the antenna with the MFJ analyzer. Here are the results.

<u>#18 Speaker Wire EFZ</u>			
<u>Frequency</u>	<u>SWR</u>	<u>R</u>	<u>X</u>
4.8 (Dip)	2.4	46	40
7.03	12.7	7	32
10.105 (Dip)	3.3	75	70
14.05	19.3	555	289
20.7 (Dip)	7.3	15	49
21.04	7.5	15	51
26.2 (Dip)	2.0	24	6
28.05	3.3	15	12

[July 2009 - Flight of the Bumble Bees](#). Three of the five stations at our site used W3EDP type antennas. W0ESE and K9ZTV used configuration A with good success and I had my speaker wire EFZ. I also set up my [Crappie Pole Crossed Dipole](#). While I made a few contacts on the EFZ, the workhorse for me during this event was the dipole. Using the two antenna ports on my K2, it was easy to switch back and forth between antennas. There was a noticeable reduction of receive signal strength with the EFZ and as with the prior event, the signal reports were poor.